

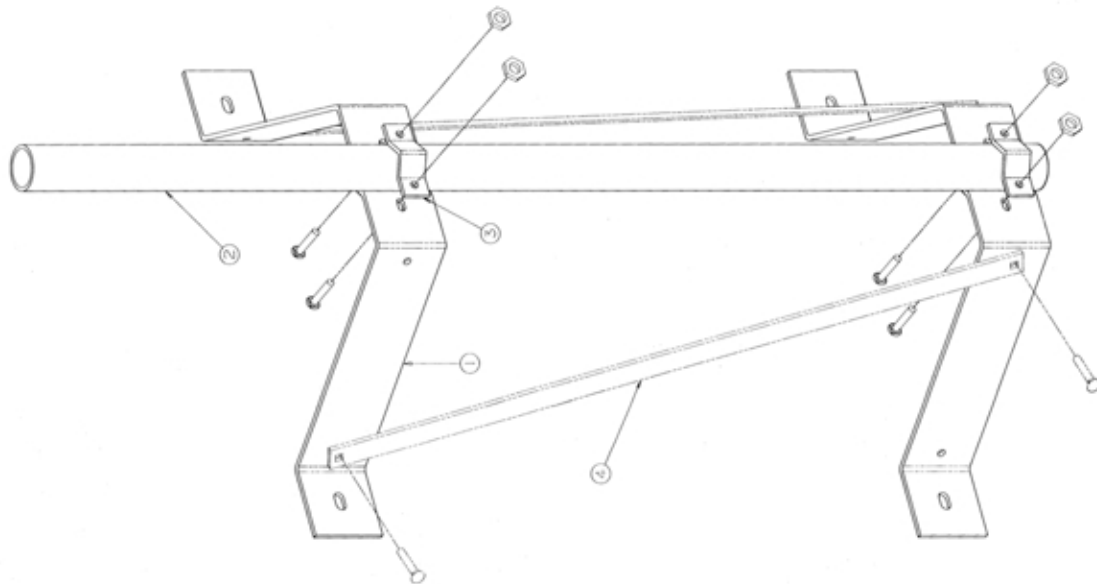

# ROHN.

WM312 WITH WMB12A OPTION

HOT DIP GALVANIZED  
AFTER FABRICATION



## BILL OF MATERIAL FOR WM312

ITEM	QTY	PART NO	DESCRIPTION
1		FH100HDW	HARDWARE PACK F/WM212 & WM312
2	1	FH105	PIPE 72" X 3" X 5CH40

## BILL OF MATERIAL FOR FH100HDW

ITEM	QTY	PART NO	DESCRIPTION
1	2	FH100	BRACKET 27-5/16 < 4 X 1/4
3	2	WY23	CLAMP LADDER .25 X 1.5 X 7.15
4	230005		NUT 3/8-16 HEAVY HEX
4	210503 [R2]		BOLT 3/8-16 X 4-1/2 "T CARR. G5 HOC
4	230007		PAL NUT 3/8
1	740038		DANGER "READ INSTRUCTIONS" LABEL
1	FORM932754C-A		FORM SAFETY SHEET"
1	FORMC990109		ASSEMBLY DETAILS F/WM212 & WM312
2	720006		POLY BAG 9 X 13 X 4MILL
1	740224		WM212 P/N LABEL

## BILL OF MATERIAL FOR WMB12A OPTION

ITEM	QTY	PART NO	DESCRIPTION
4	2	WMB12	STRAP 3/8 X 1/4 X 1-1/4
4	2102736		BOLT 3/8 X 1 CARRIAGE G5
4	230005		NUT 3/8-16 HEAVY HEX
4	230007		PAL NUT 3/8
1	740224		WMB12A P/N LABEL
1	720006		POLY BAG 9 X 13 X 4MILL

## BILL OF MATERIAL FOR HMK18M OPTION

ITEM	QTY	PART NO	DESCRIPTION
4	2102566		THREADED ROD 1/2-13 X 16"
8	230013		NUT 1/2-13 HEAVY HEX
8	2500356		WASHER 1/2 STD FLAT
8	230011		NUT 1/2 PAL
1	380163		SILICONE RUBBER SEALANT
1	710117		CARTON 1-3/4 X 3-3/4 X 24-1/8
1	720006		BAG POLY 9 X 13 X 4MILL
1	FORMD85001B		HMK ASSEMBLY SHEET"
1	FORM932754C-A		SAFETY SHEET INFO
1	740224		HMK18M P/N LABEL

**ROHN.**

FRANKFURT, INDIANA 46041

TITLE WM312 WITH OPTIONAL WMB12A PACKAGE

DATE 11-24-06  
 DRAWN BY [REDACTED]  
 CHECKED BY [REDACTED]  
 APPROVED BY [REDACTED]  
 PART NO. WM312 WITH OPTIONAL WMB12A PACKAGE  
 DRAWING NO. D9B0032R1  
 REVISIONS [REDACTED]

1. IT IS THE PURCHASER'S RESPONSIBILITY TO VERIFY THAT HIS INSTALLATION AND BUILDING SYSTEM WILL WITHSTAND ALL LOADS IMPOSED BY HIS ANTENNA SYSTEM.
2. ANTENNA INSTALLATIONS SHOULD BE GROUNDED BY THE INSTALLER TO MEET ALL APPLICABLE CODES.
3. INSPECT THE MOUNT AND ANTENNA EVERY 6 MONTHS.
4. OPTIONAL ROHN HARDWARE MOUNTING KITS MAY BE PURCHASED SEPARATELY FROM ROHN. (PART NO. HMK18M)
5. ALL PARTS ARE HOT DIP GALVANIZED AFTER FABRICATION.
6. FOR ENGINEERING REPORT, REFER TO DRAWING NUMBER D9B0020.
7. PAL NUTS ARE PROVIDED WITH ALL BOLT ASSEMBLIES.
8. LOCAL ZONING AND/OR BUILDING CODES AND INSURANCE COMPANIES MAY REQUIRE AN ARCHITECT OR STRUCTURAL ENGINEER APPROVAL PRIOR TO INSTALLATION.