

55G BRACKETED ALLOWABLE ANTENNA AREAS

Tower Height (FT.)	Bracket Elevation		Allowable Antenna Areas (SQ. FT.)		
	Upper (FT.)	Lower (FT.)	70 MPH	80 MPH	90 MPH
40	30.0	15.0	72.4	54.5	41.8
50	36.0	18.0	68.7	51.7	39.4
60	46.0	23.0	65.8	49.5	37.6
70	56.0	28.0	63.5	47.5	36.0
80	66.0	33.0	61.4	46.0	34.6
90	66.0	33.0	30.6	22.0	16.0
100	66.0	33.0	16.0	10.5	6.4

55G

1. Tower designs are in accordance with ANSI/EIA-222-F.
2. All towers must have "fixed bases". Pinned bases must not be used.
3. Designs assume two 7/8" transmission line on each face (total=6), symmetrically placed.
4. Antennas and mounts assumed symmetrically placed at tower apex.
5. Allowable antenna areas assume all round antenna members.
6. Allowable flat-plate antenna areas, based on EIA RS-222-C, may be obtained by multiplying areas shown by 0.6.
7. All brackets are to be ROHN (P/N HBUTVRO).
8. The interface of tower brackets to supporting structure is to be designed by others and must support a minimum horizontal force of 3200 lbs.

FOUNDATION INFORMATION

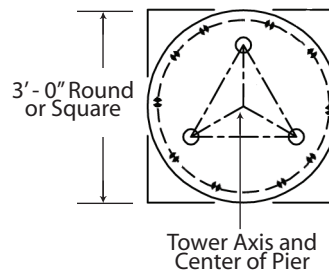
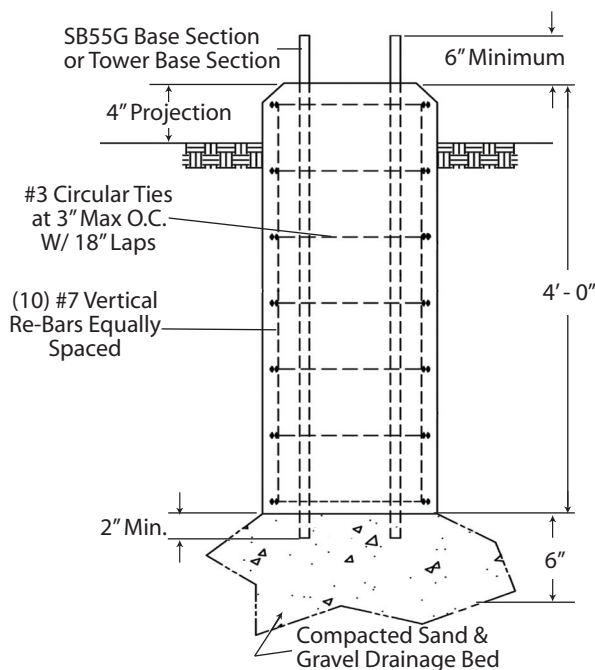

MAX REACTIONS		VOLUME OF CONCRETE	
Moment	= 4,180 ft. lbs.	Square Pier	= 1.4 cu. yds.
Shear	= 634 lbs.	Round Pier	= 1.1 cu. yds.
Vertical	= 1,340 lbs.		